

Webster
Knolls
Handbook

**WEBSTER KNOLLS HOMEOWNERS ASSOCIATION
HANDBOOK**

Revised September 2023

TABLE OF CONTENTS

<u>Category</u>	<u>Page</u>
I. General Information	3
II. Introduction	3
III. Homeowners and Association Responsibilities	4
IV. Service Request/Association Procedures	6
V. Complaint Procedures/Penalties	6
VI. Assessment Payments	6
VII. Pets	7
VIII. Exterior Building/Landscape Changes	7
IX. Parking and Motor Vehicles	11
X. Driving Regulations	12
XI. Noise Pollution	12
XII. Rental of Townhouse Units	12
XIII. Use of Townhome	13
XIV. Trash Storage and Removal	13
XV. Miscellaneous	14
XVI. Insurance Deductibles	15
XVII. Fining Procedures and Process	15
Responsibility Matrix	16
Appendix A, Deck	19
Appendix B, Fence	21
Appendix C, Storm Doors	22
Appendix D, Satellite Dish	23
Appendix E, Awning	24
Attachment F, Fine Schedule	25
Variance Request	26

I General Information

A. Emergency Phone Numbers

<input type="checkbox"/>	Fire	911
<input type="checkbox"/>	Ambulance	911
<input type="checkbox"/>	Sheriff	911
<input type="checkbox"/>	State Police	279-8890
<input type="checkbox"/>	Dog Warden	872-7009
<input type="checkbox"/>	Spectrum	833-267-6094
<input type="checkbox"/>	Refuse/Recycling	352-3900
<input type="checkbox"/>	Green Light	833-588-6599

- B.** If you detect a gas odor, leave your residence immediately, go to a neighbor's house, and then call either RG&E or 911.
- C.** To request maintenance, pay assessments, or to answer your questions, please contact the Webster Knolls managing agent's or go online to croftoninc.com.

Crofton Perdue Associates, Inc.
111 Marsh Road, Suite 1
Pittsford, New York 14534
Phone: (585) 248-3840
E-mail: info@Croftoninc.com
Website: www.croftoninc.com

Office hours are 8:30 AM to 5:00 PM – Monday through Friday.
In an emergency, nights, holidays and weekends, call the appropriate authority first, then call 248-3840.

II. Introduction: Welcome to Webster Knolls

A. General

1. Webster Knolls Homeowners Association, Inc. (hereinafter referred to as WKHA) is a shared living community. The community welcomes all to share all it has to offer, but also asks that its members understand that living in a shared community has not only rewards and benefits, but also imposes certain obligations and restrictions upon the residents and their guests. These obligations and restrictions should not be seen as penalties for living here, but should be understood to be pathways to assure the comfort and safety of all residents, as well as, a method to control costs and help the community prosper. Additionally, the rules and regulations help us all to protect our investment in our community, and help protect the value of our properties. Residents and their guests are entitled to enjoy the property, but in doing so are expected to observe the Rules and Regulations of the Association.

2. The Rules and Regulations included herein have been approved by the Board of Directors of the WKHA in conformance with the terms and conditions of the WKHA Declaration of Covenants. This document is supplemental to the provision of the WKHA Declaration of Covenants and the By-Laws relating to the rights, privileges, and duties of the Homeowners. The rules and regulations in this document are subject to change, by either owner consensus (as detailed in the Declaration of Covenants Article XII, section 1, page D-23), or as the Association deems necessary.
3. Any activity and/or modification to a resident's unit and/or the landscape area, unless it is approved by the Rules and Regulations or the WKHA Declaration of Covenants and the By-Laws, is prohibited. The only way an activity and/or modification can occur or be performed is by an approved variance.

B. Definitions

1. Association: WKHA: all WKHA Homeowners.
2. Managing Agent: Crofton Perdue Associates, Inc. and its successors.
3. Board of Directors: The Board of Directors of the Association, as elected by the members of the Association.
4. Homeowner: An owner of a townhome (including non-resident owner).
5. Lot: The deeded land under and behind each townhome, which extends twelve (12) feet out from the rear of the home over the width of the rear of the townhome.
6. Property: The townhomes, lots, and common areas affected by the Declaration of Covenants.
7. Common area/ground: The area outside the deeded property of each townhome.

III. Homeowners and Association Responsibilities

A. Association

1. In general the Association shall maintain and repair the exterior of all homes as outlined in the declaration of covenants or modified by the Board of Directors within the guidelines of the offering plan. The Association shall maintain, replace and care for roofs, gutters, downspouts, and the exterior of building surfaces. The Association will also maintain and repair all walkways, driveways, private roadways and privacy fences installed by the builder.
2. The Association shall maintain and repair (and replace when applicable) the common area landscape. This includes mowing, fertilizing, insect control, reseeding, weeding, trimming and mulching (see section VIII-F for exception based on homeowner planting and gardening preferences). This also includes shrubs or trees planted in the common areas by individual homeowners with approved variances. Flowers planted in the mulch beds, by the homeowner, shall not be maintained by the Association and the Association will not be responsible for any damage to flowers within the mulch beds (see section VIII-F).
3. The Association is responsible for providing snow removal from driveways, sidewalks, and Association roads. Snow removal shall occur when the depth of the fallen snow reaches 3 inches or greater over 50% of the project. For snow removal at other times, such as blowing and drifting conditions that cause an impediment to

travel, please contact the managing agent. Kennington, South Estate, and Deerhurst roads, while within the confines of Webster Knolls, are the responsibility of the Town of Webster, Department of Public Works. Any concerns about the plowing, or maintenance, of these roads should be directed to them.

4. The Association will maintain all common area lighting, i.e. post lights installed by the Association.
5. The Association is responsible for providing garbage collection from each unit (see Section XIV).
6. The Association shall be responsible for the removal of any bees/wasps or any other insects from the dwelling, that are detrimental to the structure or harmful to humans provided the action can be accomplished from the outside of the dwelling.
7. The Association will provide insurance for the structure as well as common area liability and a common area umbrella policy.

B. Homeowner

1. The Homeowners shall maintain, repair and replace the interior of his or her townhome. This includes, but is not limited to, the repair and maintenance of all interior painting, plumbing, electrical, heating, central air conditioning, appliances, attic power vent motor and fan, window (frame and glass), basement walls, dry wall foundations, glass surfaces, storm doors, garage pedestrian door, interior mechanization of garage doors, storm windows, screens, heat pump, the patio area, hosebibs, and outside light bulbs and fixtures attached to the unit (patio, front porch, garage).
2. The homeowner shall clean furnace and fireplace chimneys periodically to maintain safe operation. Damage expenses incurred due to not maintaining these items are a homeowner's responsibility.
3. The Resident is requested to water lawns, trees, shrubs and flowers in individual front and rear yard areas except when restricted by local government.
4. To allow Homeowners a degree of flexibility in individualizing the front landscaping (mulch beds) of their units, section VIII-F permits the planting of flowers in the beds. If a Homeowner invokes this privilege, the homeowner assumes the responsibility of maintenance of the shrubs (e.g. trimming) and weeding of the mulch beds, to avoid conflicts and damage to your plantings that might occur during trimming and weeding by an Association Contractor. Even if a Homeowner assumes the maintenance responsibilities of the mulch beds when flowers are planted, the exterior maintenance of the units, and lawns, still belongs to the Association. Since there are occasions that the flowers may interfere with these maintenance activities, the homeowner assumes the risk of damage. In both these instances, the Association shall not be held responsible for any damage that may occur to the flowers by an Association Contractor.
5. Homeowners are responsible for maintaining lawn areas that are inaccessible by mowers.
6. Any control or elimination of bees, wasps, insects, and/or animals requiring any action or maintenance within the dwelling unit shall be the responsibility of the unit's owner.

7. Any damage to the landscape and/or to the exterior of a townhouse caused by the homeowner must be repaired by the homeowner to its original condition.
8. It is strongly recommended that each homeowner have insurance to cover their personal contents, internal structural changes, personal liability as well as umbrella coverage. The Association's insurance deductible is a homeowner's responsibility.
9. The use of any contractor by the homeowner requires that the homeowner/contractor provide a certificate of insurance to the Managing Agent before any work is performed. This will protect the homeowner in case of an accident.

IV. Service Requests/Association Procedures

- A. All requests for service to the exterior of any unit or to the Common Areas should be brought to the attention of the Managing Agent. The Managing Agent will be responsible for directing the request to the appropriate channels for consideration and action. The Managing Agent will also inform the Homeowner if a particular request is not the responsibility of the Association, and will attempt to provide counsel for the Homeowner in resolving such requests.
- B. All Homeowner suggestions or requests concerning procedures may be directed to the Managing Agent. The Managing Agent will see that the matter is brought to the attention of the appropriate individuals for consideration or response to the Homeowner.

V. Complaint Procedures/Penalties

The Managing Agent is charged with overseeing compliance with the rules and Regulations and is directed to advise the Homeowner, where appropriate, by letter detailing specific non-compliance items and requesting appropriate corrective action. Continued non-compliance will be brought to the attention of the Board of Directors for appropriate action (see section XVII).

VI. Assessment Payments

- A. Assessment payments must be made to the Association on a monthly basis to allow for the proper operation of the Association.
- B. All monthly assessment payments are due the first (1st) day of each calendar month. A late fee shall be due and payable on delinquent accounts for which there is a balance due of fifteen dollars (\$15.00) or more. An account will be considered delinquent if payment is not received at Crofton Perdue Associates' office by the fifteenth (15th) day of the month.
- C. For convenience, residents may choose to make arrangements with their bank to have the monthly assessment paid automatically or contact Crofton to arrange for ACH.

VII. Pets

- A. Homeowners are allowed no more than two dogs
- B. Homeowners must register and immunize every dog in accordance with the local laws and requirements.
- C. Household pets that are confined to a townhouse shall not cause a nuisance, unreasonable disturbance and/or sanitation problem for other community members and their homes.
- D. The pet owner has the sole responsibility of controlling and cleaning up after his or her pet in all common areas and rear patio area. The pet owner must clean up after his or her pet when walking anywhere in Sumnol, Summit Knolls or WKHA areas. Any damage costs resulting in failure to comply with this rule will be assessed to the homeowner. Pet waste clean-up services are recommended, and upon requests, names may be obtained from Managing Agent.
- E. No dog or cat may be left unattended in any common area. While in any common areas all dogs or cats must be restrained at all times by the use of a hand- held leash not to exceed eight (8) feet in length.
- F. Dog houses, staking out or fencing in of any pet in the common area is prohibited.
- G. The placement of pet food on patios or balconies for consumption by pets is prohibited. The confinement of pets on patios or decks is prohibited.
- H. Pet owners are required to immediately remove their pet's excrement from common area and dispose of it properly.
- I. Homeowners have the right to call the Webster Dog Warden if these rules are violation.
- J. Residents in violation of these Pet Rules are subject to fines.

VIII. Exterior Building/Landscape Changes

A. Changes/Additions

1. No exterior changes, modifications, alterations or additions to the townhome or landscape, including installation of central air conditioning, are permitted without a variance request, approved by the Board of Directors. Detailed specifications must be provided. Applications must be made on a WKHA Variance Request Form. Blank forms are available from the managing agent or from the Crofton Perdue web site. No work should commence until an approved variance request is received by a Homeowner. The granting of approval by the Board of Directors does not relieve the responsibility of the Homeowner to comply with any applicable building code or ordinance.
2. Any approved changes are subject to inspection and approval by the Board of Directors for workmanship and adherence to variance request. Homeowners shall not use workers for exterior work who are not covered by Contractor's Insurance. A certificate of insurance must be attached to the variance request.
3. Homeowners are responsible for maintaining any new or existing exterior changes, modifications, alterations or additions, including but not limited to, decks and fences. If the Homeowner fails to maintain same, the Association shall notify the Homeowner to perform the maintenance and/or repair within forty-five (45) days. If the Homeowner thereafter fails to maintain and/or repair within the designated time, then the Association has the right to maintain and/or repair same, and bill the homeowner for services rendered. Any damage to the landscape and/or a townhome by the homeowner must be repaired to its original condition at the homeowner's expense.

4. Any landscaping changes or additions in common areas become the property of the Association.
5. The following changes/additions are not permitted under any circumstances.
 - a. Window air conditioners
 - b. Newspaper boxes
 - c. Screening of garages
 - d. Lawn ornaments or decorative objects in common lawn areas
 - e. Window awnings
 - f. Bird feeders in the common lawn areas, unless hung from a tree high enough not to interfere with the lawn mowing.
 - g. Exterior clotheslines
 - h. Exterior radio or television antennas
 - i. Wind chimes
 - j. Flags (except for an American flag)
 - k. No decorative items such as wreaths or flowers can be attached to the units.
6. Deck awnings, (*per specification), are permitted with Board approval by variance.
7. Satellite dishes are permitted with Board approval by variance.
8. Lawn ornaments (maximum of 4 and not over 36 inches high), Shepherds hooks (for either plants or bird feeders), American Flag (no larger than 12" x 16") are permitted in shrubbery beds. Lawn ornaments, shepherds hooks, and American flags must be placed so as not to interfere with maintenance of the shrubs and mulch beds. Since there are occasions when these items may interfere with maintenance activities, the homeowner assumes the risk of damage. The Association shall not be held responsible for any damage that may be incurred by an Association Contractor.
 - a) Any ornaments which the Board of Directors considers to be of an offensive nature or does not meet the community's décor must be removed immediately upon request.
9. Railings in the front of a townhouse are permitted for safety reasons. The railing location and material must be approved by variance before installation.
10. If a wheel chair ramp becomes, or is necessary, a variance request must be submitted.
11. No dwelling unit owner shall paint the exterior surfaces of windows, walls, or door openings of their dwelling unit.
12. Malibu lights are permitted subject to variance approval.
13. Pavers and/or stepping-stones are allowed in front beds if they are installed level to the ground and are not a hazard to anyone walking in the front beds.

B. Tree Variance Specifications and Procedures

1. Homeowners are encouraged to plant trees around their homes; a variance request must be submitted.
2. As each unit is unique in its relative location to its neighbors, the Board of Directors is unable to standardize the allowed locations. Any variance request must be accompanied by a sketch pinpointing the location of the proposed planting, stating the distance of the tree from the subject unit and surrounding neighbors.
3. Homeowners are responsible for underground utility stakeout prior to excavation. The number is 1-800-962-7962.

C. Deck/Fence Variance Specifications and Procedures

1. Following the procedures listed below will assist the Board of Directors in making a timely decision on a Homeowner's variance request.
2. The Homeowner must use the WKHA Variance Request Form.
3. The Homeowner must provide an accurate layout of the deck/fence to be constructed. Be sure to include all dimensions, including height from the ground.
4. The Homeowner must provide a layout of the deck/fence in relation to the unit and any adjacent units. Label the layout properly. Include addresses, dimensions of the deck/fence, distance from deck/fence to any adjacent neighbors, locations of utility meters and/or air conditioning units. Window locations of adjacent units are also required. Maintenance of lawn areas inside the fence becomes the sole responsibility of the Homeowner.
5. The following deck specifications must be followed:
 - a) Call the Town of Webster for a permit.
 - b) Call for a utility stakeout. This number is 1-800-962-7962.
 - c) The deck can extend up to twelve (12) feet out from the back of your home, as measured from the basement wall.
 - d) The deck must be made of pressure-treated lumber and/or synthetic decking. Synthetic decking color must be approved by the Board.
 - e) The deck must contain the required railing. However, a railing is not required on ground-level decks.
 - f) The preferred treatment is a good quality wood tone stain or clear coating (such as Thompson's Water Seal) with UV Protectors. A wood tone paint may also be used. Other color paints may be considered but must be approved by a variance.
 - g) Lattice is approved skirting for the deck. It may also be used for safety purposes on units with walk-out basements and raised decks. Maintenance-free fiberglass or vinyl material is required.
 - h) See diagrams in Appendix A.
6. The following fence specifications must be followed: The fence must not extend out beyond twelve (12) feet from the basement wall of the structure.
 - a) Pressure-treated lumber and/or synthetic material must be used. Synthetic lumber color must be approved by the board.
 - b) The fence must not exceed a height of six (6) feet.
 - c) Fences must be approved by the Board of Directors before construction. (The Board of Directors will review the location of the proposed fence in relation to any adjacent townhouse.)
 - d) The fences must be constructed using 1x6 board-on-board design.
 - e) The approved style for the top of the fence is "dog-eared".
 - f) Fences must be horizontally level.
 - g) Owners are responsible for obtaining the appropriate approval (building permit) from the Town of Webster.
 - h) The Homeowner must call for a utility stakeout at 1-800-962-7962.
 - i) No fence shall be attached to any townhome structure.
 - j) The approved treatment is specified in VIII, C-5. f.
 - k) See Appendix B for diagrams.
 - l) All fences must have an access to the enclosed area so that the Association can perform maintenance to the exterior of the unit.

D. Flag Pole Specifications and Procedures

1. The flag of the United States may be flown on any day, from sunrise to sunset, when weather permits.
2. No other flags, banners or windsocks are permitted to be displayed. (Refer to Section VIII, A. 8. for exemption.)
3. Flagpole brackets may be attached to the exterior garage overhead door side framing closest to your sidewalk, to support posts on entry porches, to the exterior trim of the front door or to the back privacy fences. Flags may not exceed 3' x 5'.
4. Brackets must be aluminum or material that will not rust.
5. The Homeowner is responsible for any damage to the exterior arising from the placement of the bracket and replacement thereof.
6. American flags (no larger than 12" X 16" as stated in Section VIII-A.8.) may be displayed in the landscape beds.

E. Sign Regulations

1. No advertising signs other than Security or For Sale signs are allowed to be placed on the property.
2. Only 1 *For Sale* sign no larger than four (4) square feet is permitted in front of the home. Sign must be removed when home has been sold.

F. Planting and Gardening

1. Residents are permitted to plant flowers in their back yard patio area, tree beds and shrubbery beds. Homeowners are responsible to maintain the flowers in good order.
2. Any plantings of trees and/or shrubs approved by the variance procedure become the maintenance responsibility of the homeowner.
3. Residents may place flowerpots on the front stoop with the following restrictions:
 - a) The number, size, and placement of flowerpots shall not interfere with the safe ingress or egress to and from the unit.
4. Flowers may be planted in your patio area, if maintained by the Resident.
5. A Resident may not attach anything to the trim or siding, except where permitted by the handbook.
6. A Resident may hang a small planter on the front porch or in the rear of the unit, provided it is not secured to the vinyl siding.
 - a) Hanging hardware must be aluminum, stainless steel, or material that will not rust.
 - b) The Homeowner is responsible for any damage to the exterior arising from the placement of the hardware.
7. Vegetable plants are not permitted (except in the patio area).
8. The mulching of the common area shrub beds is currently done annually.

G. Holiday, occasion, and seasonal decorations

Temporary exterior decorations may be displayed providing:

1. Holiday decorations are allowed from Thanksgiving through January 15th.
2. Halloween decorations are permitted for 10 days before and 7 days after.
3. Holiday, occasion, and seasonal decorations are also permitted on the stoop and front shrub beds with the following conditions:
 - a) Occasion and seasonal decorations must meet approved dimensions and quantity. See Section VIII, A. 8.)
 - b) No lights may be placed on the front shrubs prior to Thanksgiving and must be

removed by January 15.

- c) Any occasional or seasonal decorations must be of a manner that they do not interfere with the shrub bed maintenance.
4. Other than the front door, Residents may not attach decorations to the exterior of their unit, with the exception of holiday lights, which may be hung using gutter clips only.
5. Holiday lawn decorations are permitted. However, the Homeowner accepts the risk of damage to the decorations by snow removal or lawn care equipment, and damage that may be caused by any resulting debris. Additionally, the Homeowner is responsible for any damage caused by the lawn decorations to the lawn, snow removal equipment, or lawn care equipment.
6. Any decorative items, or decorations, which the Board of Directors considers to be of an offensive nature or does not meet the community's décor, must be removed immediately upon request.
7. Nothing can be hung from the trees except lights.

H. Screen/Storm Door Specifications:

1. Use of a storm door in conjunction with an insulated metal exterior door can result in excessive heat buildup between the doors and can cause melting of plastic molding decorations. This problem is considerably more likely to occur if the inside door is a dark color and if the doors are exposed to direct sunlight. Homeowner is responsible for exterior door repair should any damage occur.
2. The storm/screen door must be white.
3. There is no restriction on where such door may be purchased.
4. The Homeowner must submit a variance request form for approval to install same.
5. See diagrams in appendix C.

IX Parking and Motor Vehicles

- A. Each Resident has exclusive use of his/her garage and driveway for parking vehicles. Parking is prohibited on the private roads. Parking cars side by side is not permitted in your driveway.
- B. All private roads within Webster Knolls are designated fire lanes with these exceptions: the private access lanes along South Estate Drive, Kennington Blvd. and Deerhurst Road. Parking is **NOT** permitted in the fire lanes and vehicles parking in the fire lanes will be ticketed and/or towed.
- C. Visitor parking within Webster Knolls is for use by visitors, not homeowners. No resident has exclusive use of any of these spaces. No vehicles may be parked in any of the visitor spaces for more than 48 hours.
- D. No boat, trailer, mobile home, camper truck, motor home, recreational vehicle, snowmobile, or other similar vehicle shall be parked in the development for more than 72 hours. No vehicle larger than a one-ton pick-up may be parked on the roadways and driveways.
- E. There is no parking on lawns at any time.
- F. Any Homeowner's or guest's automobile, truck, trailer, camper, motor home, recreational vehicle, snowmobile, other similar vehicle, or vehicle attachment that causes damage to asphalt roads, driveways, or lawn areas will be responsible for the repairs to same.
- G. Visitor and temporary parking on non-fire lane access lanes parallel to town roads,

(South Estate, Kennington, and Deerhurst) are permitted. However, no person shall park a vehicle so as to obstruct a unit owner's ingress or egress to garage or driveway or to obstruct snow removal. The Board of Directors reserves the right to make these private drives a fire lane road.

- H. Any vehicles in violation of the above rules will be towed at the owner's expense.
- I. Repair and delivery vehicles shall be permitted on the property for such periods of time as are reasonable for the accomplishment of repairs or deliveries.
- J. No Major repair of vehicles are permitted on in any common area or driveways.
- K. Any vehicles leaking oil, antifreeze etc. must be parked in the garage or off premises until it has been repaired. Cleanup and repairs are the responsibility of the homeowner.
- L. Portable On Demand Storage - Residents may have no more than two Portable On Demand Storage (PODS) units in their driveway at any time. The PODS are allowed for a maximum of 72 hours. After 72 hours, a fine of \$50 per day will be assessed.

X Driving Regulations

- A. The speed limit is 15 miles per hour on private roadways. All Residents are asked to remind family members and their guests to drive slowly and carefully.
- B. Unlicensed motor vehicles (other than those operated in the course of common area maintenance) shall not be operated anywhere on the property and private roads at any time. This specifically includes snowmobiles, mini-bikes, powered scooters and the like.
- C. Parents are expected to closely supervise their children's bicycle habits. Bicycle riding is not permitted on any lawn area.

XI Noise Pollution

- A. There must be no loud or unusual noise from any radio, stereo, television, tape recorder, muffler, or any sound-producing device which will disturb the comfort of others at any time, day or night.
- B. Residents shall comply with the Town of Webster noise ordinance.

XII Rental of Townhouse Units

- A. Each townhouse owner has the right to rent, lease, mortgage, or convey his or her Townhouse unit for single family occupancy for terms of 12 month or longer leases.
- B. Association assessments are the personal obligation of the owner of record for the townhouse unit.
- C. Any owner who rents or leases his or her townhouse to another party must inform the party of the requirements of the Declaration of Covenants, Conditions and Restrictions, By-Laws, and this Rule Book. Copies of these documents must be included in the lease. Copies of this document are on the Crofton Perdue Website.
- D. The owner of the townhome will be responsible for repair or rebuilding as necessary on the lot or home due to damages caused by renters or their guests.
- E. The owner is held responsible if a renter fails to conform to the Rules and Regulations.

XIII Use of a Townhome

- A. The townhome shall be used for single family residential purposes only, in conformance with the uses set forth in the Declaration.
- B. No noxious nor offensive activity shall be carried out in any townhome, or in the common areas, nor shall anything be done therein either willfully or negligently, which may become an annoyance or nuisance to other townhome owners or occupants.
- C. Only electric, propane, or charcoal grills, are allowed for outdoor cooking:
All grills must be:
- Contained in appropriately maintained units.
 - Operated under direct supervision at all times during use.
 - Positioned at least 10 feet away from any structure or vegetation.
 - Never used inside garages or enclosed areas.
- The use of smoker grills, including pellet smokers, offset smokers, or any grill designed for smoking food is strictly prohibited.
- D. Recreational fires are not permitted.
- E. Nothing shall be done in any townhome or common area which would impair the structural integrity of any building or structurally change any building.
- F. Resident shall not cause or permit any unusual or objectionable noise or odors to be produced in or emanate from their units.
- G. No Resident, or any of his or her agents, employees, licensees, or visitors shall, at any time, bring into or keep in his or her unit, any flammable, combustible or explosive fluid, material, chemical, or substance, other than common household items (e.g. stains, cleaners, nail polish remover). These items must be stored in approved containers when not in use.
- H. Firing or discharge of guns, air pistols, fireworks or other weapons is not allowed within the Webster Knolls Homeowners Association.
- I. Nothing shall be done or kept in any townhome or common area, which would:
1. Increase the insurance rate for any building or its contents.
 2. Cause cancellation of the insurance covering any building or its contents.
 3. Homeowners who hire a contractor must verify that they have Workers Comp. & Liability Insurance coverage and supply a copy of the coverage to the Managing Agent before any work is performed.
 4. Or violate any laws.
- J. Webster Knolls is a residential zoned community. As such, there shall be no commercial, religious, or educational endeavors conducted, maintained, or permitted in any town home or any lot. Neither shall there be any industry, nor business, permitted that requires the use of employees, or increases delivery truck traffic above and beyond once a day. Self employed individuals, sales representatives, consultants, and other single entity professions are permitted, provided they do so in a quiet and interference free manner. Any and all business customers must observe community rules. Sales parties, such as Mary Kay and Tupperware are permitted.

XIV Trash Storage and Removal

- A. Residents shall store trash in their garages between weekly trash pick-ups.
- B. Only use metal or polyethylene waste containers with covers that close securely. Only waste containers are to be put outside the garage doors per the Declaration.
- C. Trash containers, recycle boxes or loose items should be placed in the driveway the evening before the day of pick-up. Trash containers and recycle boxes must be removed from the driveway on the evening of pick-up.
- D. If windy conditions exist while awaiting trash pick-up, residents are required to secure all trash and recycle bins in such a manner as to prevent the scattering of the contents.
- E. The Homeowner shall call the trash company to arrange for special pick-ups (i.e. refrigerators, cartons, etc.) prior to placing items out for pick up.

XV Miscellaneous

A. Garage Sales

1. The Association sponsors an annual garage sale. In the event of Association sponsored garage sales, no permission is required.
2. A garage sale, yard sale, porch sale, or similar type of sale shall not be conducted, except at the Association's annual sale.
3. Violation of this rule will result in a per day fine.
4. Estate sales at the unit of a deceased homeowner may be held for two days with prior Board approval to the family.

B. Outdoor Furniture

1. Residents are not permitted to place lawn furniture in common areas subject to the following exception: lawn furniture may be placed in backyard common areas if it is removed the same day. Lawn furniture includes items such as sandboxes, child swings, pools, etc. and should only be used in backyard open space. Any item causing lawn damage will be the responsibility of the Homeowner.

C. Solicitation

There will be no soliciting without the prior written consent of Board of Directors. Soliciting does not include activities of candidates for public office.

D. Ice Removal

To prevent damage to concrete, the only approved material for ice removal is calcium chloride. **No rock salt is permitted.** Damage caused by rock salt shall be the responsibility of the unit owner to repair or replace.

E. Basketball Hoops

Basketball hoops are permitted as long as their construction and use meets the following requirements:

1. A variance is required before use.
2. Must be of collapsible design
3. Must be stored away when not in use.
4. Must have a heavy base or a manner to secure to prevent tipping.
5. Must be used in a manner consistent with safe practices.
6. Cannot be used in any confined areas.

7. Homeowners are responsible for any damage that may occur.

F. Items Not Covered

For those items or events that are not covered by the Declaration or ByLaws or handbook the following procedure will be followed. If the Managing Agent and Board President find that an item, event or conduct that is not in keeping with the Associations décor or general standard for Webster Knolls, a fine per day will be assessed. The homeowner will be called by phone and a follow up letter will be sent. The situation must be corrected within minimum of 24 hours and at the discretion of the Managing Agent and Board President up to a maximum of 72 hours.

XVI Insurance Deductibles

The Association's Insurance coverage is subject to a deductible. The homeowner, and not the association, is responsible for the deductible and the homeowner will be **assessed the deductible fee. Since the deductibles can change frequently, current** deductibles will be communicated in the community news letter, or year end meeting minutes, to allow homeowners to adjust their individual insurance policies, if so desired. Any questions should be addressed to the Managing Agent.

XVII Fining Procedure and Process

Fines will be levied for violations of the Declaration of the Association (Articles XI and XII) and/or of the Association's Rules and Regulations. Fines will be levied after one (1) written warning, except that for parking violation situations, which prevent other residents from access to their townhouses, there shall be automatic fines (no warnings required). Fines are collected in the same manner as monthly assessments. Multiple violations of the same rule will be fined after one warning.

RESPONSIBILITY MATRIX, 3 pages

APPENDIX A -Deck Specifications, 2 pages

APPENDIX B - Fence Specifications

APPENDIX C – Storm Doors, (Only White), (Crossbuck can be with or without scallops)

APPENDIX D – Satellite Dish Specifications

APPENDIX E – Awning Specifications

Webster Knolls Responsibility Matrix	Association Responsibility	Homeowner Responsibility
---	-----------------------------------	---------------------------------

Plumbing, Heating and Cooling

Interior Plumbing		X
Exterior Plumbing	X	
Heating & Cooling Systems		X
Hose Bib (Outside Faucet)		X

Windows

Glass (Including Thermo Panes)		X
Window Frames & Sills	X	
Window Hardware (Hinges, locks etc.)		X
Painting (Interior)		X
Caulking & Weather Sealing (Interior)		X
Caulking & Weather Sealing (Exterior)	X	

Doors (Including Garage Pedestrian Door and Garage Door)

Exterior Painting	X	
Hardware Replacement/Repair		X
Structural/Replacement		X

Concrete Floors and Sidewalks

Garage		X
Basement		X
Concrete Stoop and Pavers	X	

Walls

Foundation Cinder Block - Outside surface		X
Foundation Cinder Block - Inside surface		X
Foundation Cinder Block - Structural		X
Party Walls		X
Steel Basement Columns		X
Exterior Siding & Trim	X	

Front Porch and Steps

Structural	X	
Snow Removal	X	
De-icing after Snow Removal		X
Lighting - Bulb Replacement		X
Exterior Coach Fixtures (On Brick Wall)		X
Street Post Lighting	X	

Sewers

Internal		X
External	X	

Webster Knolls Responsibility Matrix	Association Responsibility	Homeowner Responsibility
---	-----------------------------------	---------------------------------

Rainwater/Snow Melt/Sumps

Gutters	X	
Downspouts	X	
Grading of Soil (outside the homeowners deeded area)	X	
Grading of Soil (within the homeowner's deeded area)		X
Storm Water	X	
Catch basins, Laterals & Downspouts	X	
Sump Pump & Check Valves		X
Exterior Damage due to Ice Damming	X	
Interior Damage due to Ice Damming*		X

**The homeowner is responsible up to Association's deductible.*

Chimney's & Fireplaces

Interior Components		X
Chimney Liner		X
Exterior Components		X
Cap	X	
Spark Arrester		X
Structural Framing	X	
Natural Gas or Propane Conversion		X

Decks/Rear Patios/Fences*

Staining/Painting		X
Re-grading		X
Structure -Flooring & Walls		X

**Except the privacy fences installed by the Builder*

Owner Installed Improvements

Skylights & Associated Framing		X
Light Tubes		X
Damage Caused by Owner Improvements		X

Vent Installation/Maintenance

Dryer	X	
Bathroom		X
Kitchen		X
Sewer	X	
Vacuum Cleaner		X
Soffit	X	
Ridge	X	

Webster Knolls Responsibility Matrix	Association Responsibility	Homeowner Responsibility
---	-----------------------------------	---------------------------------

Roof

Shingles	X	
Underlayment	X	
Sheathing	X	
Roof Vent	X	
Flashing	X	
Interior Repairs*		X

*The homeowner is responsible up to the Association's deductible.

Common Area Maintenance

Grass	X	
Trees	X	
Shrubs	X	
Roadways	X	
Pavers	X	
Driveways	X	
Street Post Lighting	X	
Fire hydrants	X	

Services and Infrastructure

Electric - Exterior to meter		X
Electric - Meter to interior		X
Street Post Lighting	X	
Refuse & Recycling	X	
Refuse & Recycling of larger items		X
Snow Removal	X	
Pest Control - Interior		X
Pest Control - Exterior	X	
Cable TV		X
Telephone		X
Antennas/Satellite Dishes		X

Insurance - Structures & Common Areas

Fire	X	
Common Area Liability	X	
Common Area Umbrella	X	

Insurance - Personal

Personal Contents		X
Liability		X
Umbrella		X

APPENDIX A
Deck Specifications

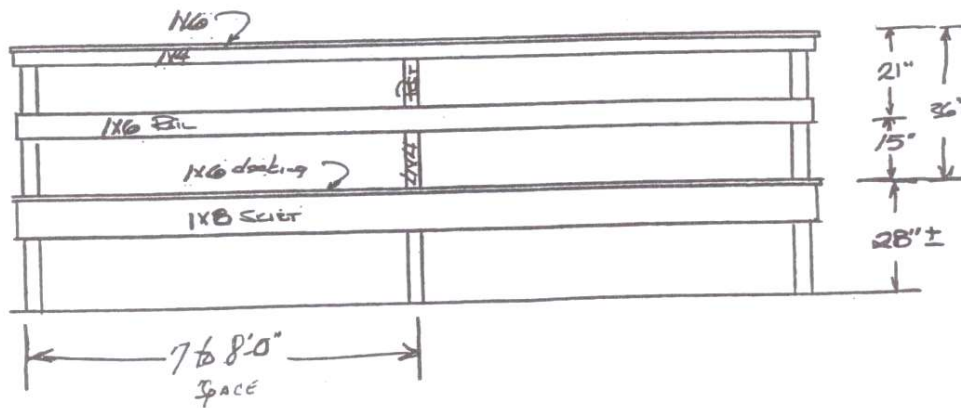
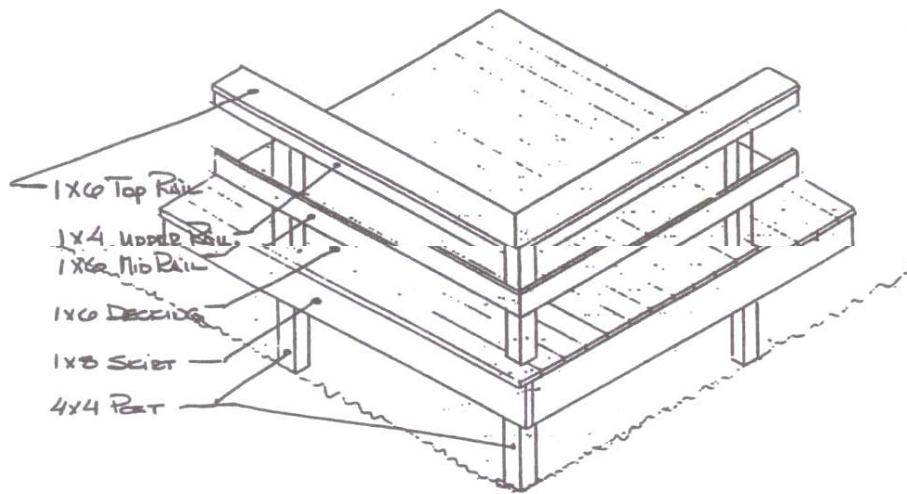

Any gaps in the railings for decking cannot exceed a 4" spacing. 11/2015

style #2

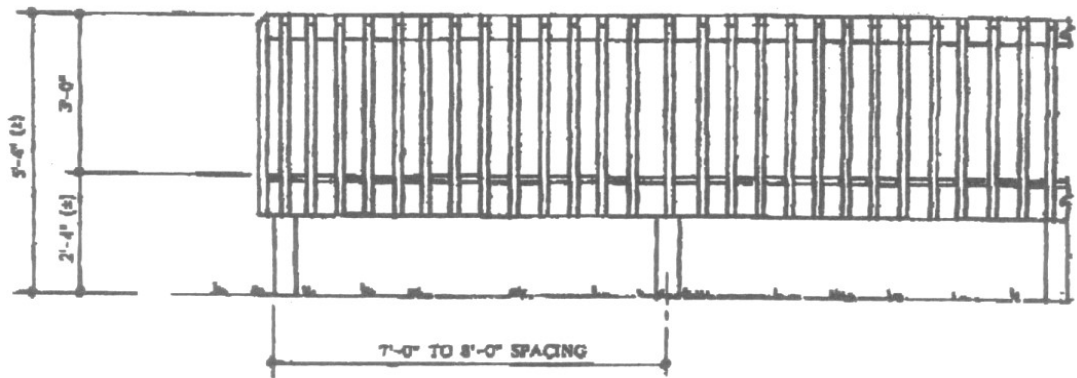
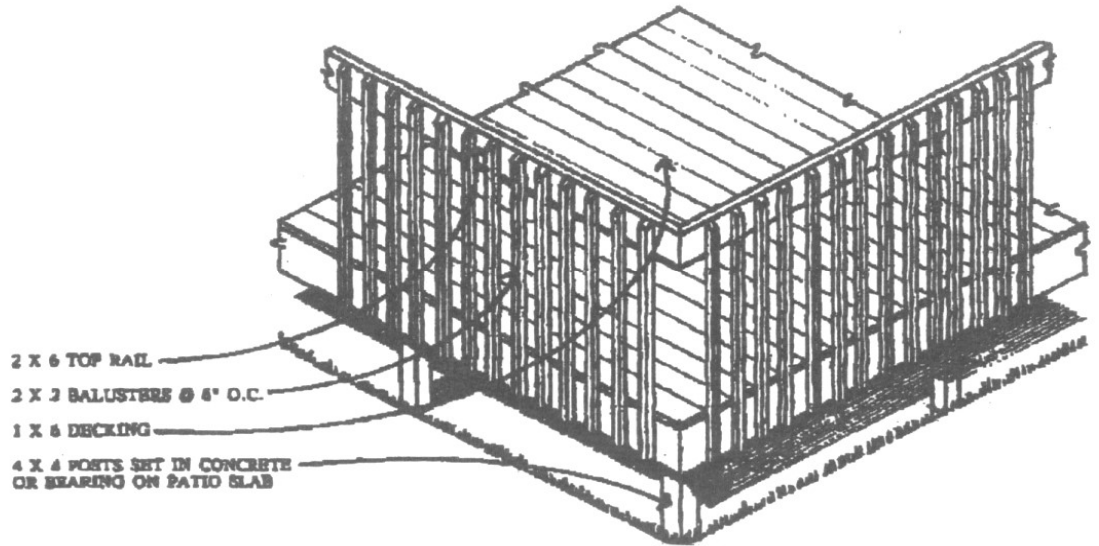

APPENDIX B

Fence Specifications

style #1

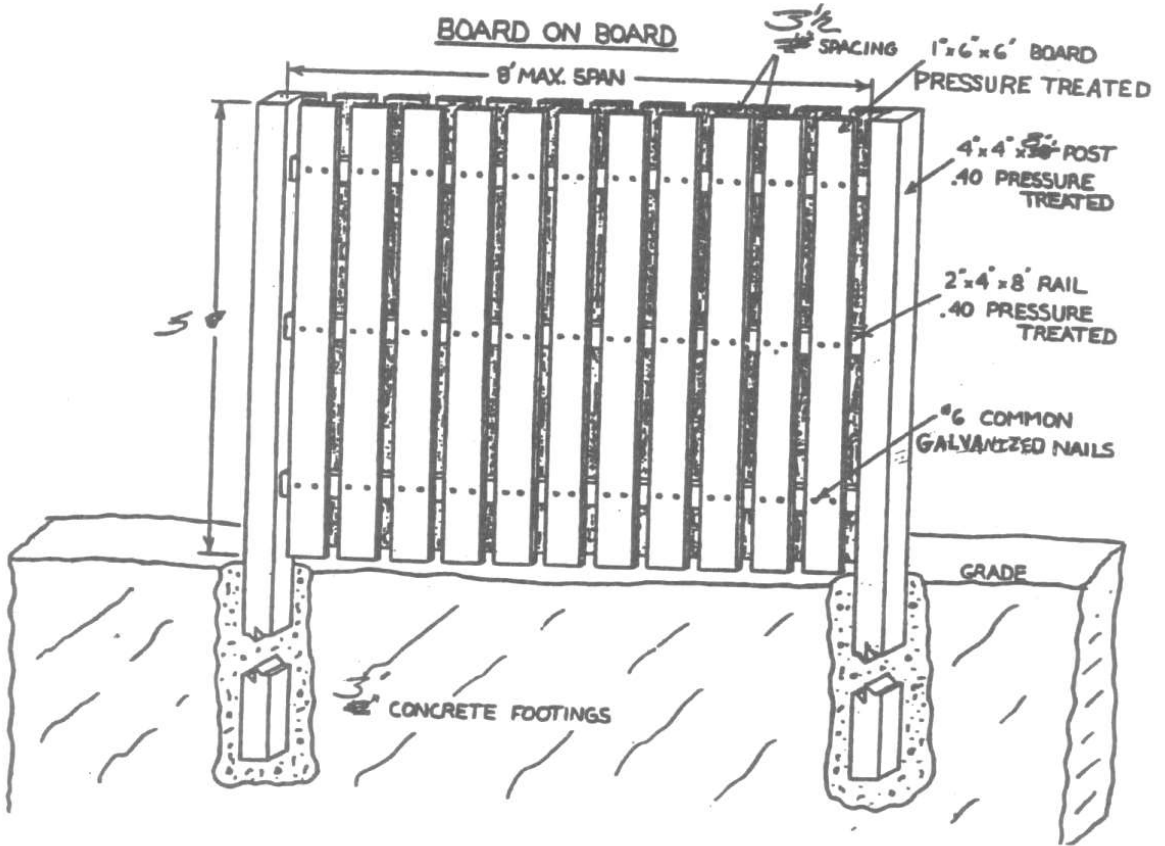

APPENDIX C

STORM DOORS – ALL IN WHITE

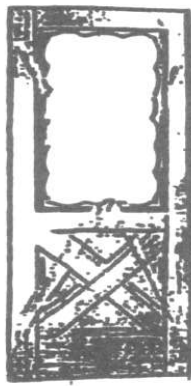

APPROVED

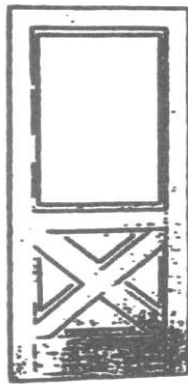

APPROVED

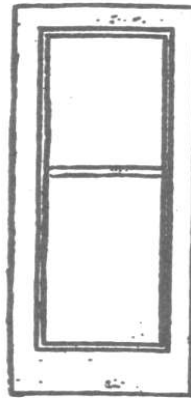

APPROVED
(self-storing)



APPROVED

APPENDIX D

WEBSTER KNOLLS HOMEOWNERS ASSOCIATION SATELLITE DISH VARIANCE SPECIFICATIONS

- A Variance Request must be submitted to Crofton Perdue Associates prior to installation, including sketch and description of exact location & means of properly mounting the dish. Contractor is to confirm reception for selected location prior to submitting the request. (A variance request can be found at the Crofton Perdue website: www.Croftoninc.com).
- The satellite dish must be professionally installed by a professional satellite dish installer and/or company. The utility stake-out must be provided by the contractor prior to installation.
- Any installation shall comply with all city and state regulations & codes.
- No satellite dish shall be mounted to the siding, roof, soffit or trim of an individual unit or on the common area.
- The Homeowner shall install a satellite dish, the size of which shall not exceed 18" in either the Homeowner's deeded 12 feet at the rear of the unit or in the front shrub bed at a location designated by the Board, its agents, and/or assigns.
- If installed in the unit's front shrub bed, the bed must be professionally landscaped to accommodate the installation of the satellite dish. Plantings must be of sufficient size, variety, and density to obscure the view of the dish during all four seasons.
- All plantings shall be pre-approved by the Board of Directors via the variance procedure.
- The Homeowner shall be responsible for the care and maintenance of the aforementioned landscaping. Dead shrubs or plantings shall be replaced by the Homeowner at his or her expense.
- The color of the dish shall be as unobtrusive as possible and in as close color harmony with the building as possible.
- The cable leading to the inside of the unit to connect the dish shall be internal to the building and shall not be run externally on the side of the building.
- The Webster Knolls Homeowners Association, its contractors, assigns, agents, servants and employees assume no liability for the installation and/or maintenance of said satellite dish, and the Homeowner shall indemnify the Webster Knolls Homeowners Association, its contractors, assigns, agents, servants, and/or employees harmless thereon.
- Contractor to provide address, telephone number, contact person, certificate of insurance for General Liability (\$1,000,000) & Workers' Compensation (statutory limits) with Webster Knolls Homeowners Association as the named insured and Crofton Perdue Associates as additional insured.
- All external locations for the installation of the satellite dish shall be properly grounded as determined by the installer. (May not be grounded to outside spigot.)
- Any damage to the structure or common areas caused by the installation of the dish shall be promptly repaired at the owner's expense.
- Lightning strike damage to the dish and associated mounting shall be the responsibility of the homeowner.
- All satellite dish repairs, roof, siding or chimney leaks/problems or any other problem associated with or caused by the installation of the satellite dish or its associated mounting shall be the responsibility of the homeowner.
- If installed on property maintained by the Association, and any maintenance requires temporary removal of the dish, the owner will be responsible for the removal and re-installation of the dish. If the owner does not remove the dish, the Association may do so at the owner's expense. The Association shall not be liable for any damage to the dish caused by the removal.
- In the event that this installation conflicts with future installation procedures, methods, or locations adopted by the Webster Knolls Homeowners Association, the Homeowner agrees to modify the installation to conform with the Webster Knolls Homeowners Association decision, all at the Homeowner's expense.
- Any permanent removal of a dish installation requires restoration of the location to its original condition by the homeowner.
- Temporary approval is subject to final inspection by the Board of Directors.

APPENDIX E

Webster Knolls Homeowners Association **Standard Retractable Awning Variance Requirements**

1. Each request will be handled on a case by case basis, based on the design of each home.
2. Complete specifications for structural changes to accommodate the installation of the awning must be submitted with any request. Include architectural renderings of any addition as it applies to the specific unit.
3. Durasol Systems, Inc., is the approved manufacturer. The model for the deck awning is #S1000.
4. If another manufacturer is to be considered, complete specifications must be submitted for review.
5. Motorized operation of retractable awning connection will be on the exterior of the unit. A wind sensor is allowed.
6. Awning fabric color and hardware and hood color will be specified.
 - A. FABRIC COLOR IS: HOSSEGOR - #6228.
 - B. Hood and hardware color will be white.
8. Valance design is: Wave.
9. The Association can reasonably require replacement of the fabric by the homeowner if it is deemed faded, torn, frayed, or in disrepair.
10. The awning is to be retracted at night or whenever there is no one at home. The awning can withstand only a 28-mph wind. This can easily occur during a sudden thunderstorm.
11. Final approval is contingent upon inspection of the completed installation.
12. Homeowner must submit a signed disclaimer as enclosed. Homeowner will advise any Successor in Title of the existence and content of this disclaimer.

ATTACHMENT F

Webster Knolls Homeowner Association

Fine Schedule for Noncompliance with Rules and Regulations

(Adopted by the Board of Directors on October 25, 2023 as Appendix F of the Rules and Regulations)

In addition to the specific powers to enforce these rules and regulations as otherwise stated herein, the Board of Directors has adopted the following schedule of fines to enforce compliance with the rules and regulations established for the Homeowner Association.

1. Unit Owners and/or their tenants who are not in compliance with any given rule or regulation will be notified in writing by letter sent by US mail. This notification will be considered a 30-day notice to the Unit Owner to correct the violation and will include a specific description of the violation.
2. The Homeowner will be given 30 calendar days to correct the violation described in the written notice.
3. The Unit Owner has a right to request a meeting with the Board of Directors to discuss the infraction and possible solutions. This meeting must be requested in writing and addressed to Property Management, Crofton Perdue Associates, Inc., 111 Marsh Road Suite1, Pittsford, NY 14534, within the 30-day period.
4. If the Unit Owner and/or their tenant is still non-compliant at the end of the 30-day period, the following schedule of fines will be initiated:
 - \$25 after 30 days of original notice;
 - \$50 after 60 days of original notice;
 - \$75 after 90 days of original notice;
 - \$100 additional after 120 days.

After 120 days the fine will be \$100 per month until compliance is rendered.

5. The Board of Directors reserves the right to levy stiffer penalties to non-compliant Unit Owners and/or their tenants. Unit Owners will be notified in writing by letter sent by US mail of such fines. Fines assessed will be immediate and irreversible.
6. Subsequent offenses, for the same violation, within a 90-day period of the date of the last violation, will be treated as a continuation of the original violation and fines will be doubled

